

CAS-7046-1

Description

Mega Cases Heavy Duty trunks are made with the highest standard and made to handle the rigors of the road. The wood that is used is a front and back filmed 9mm red hex pattern 6 layer wood. Most of the hardware used is from Penn Elcom an industry proven hardware manufacture. They are equipped with the New Magnetic castor system that will allow the caster rotate into stacking position auto-matically with out having to dangerously place hands between cases when stacking.

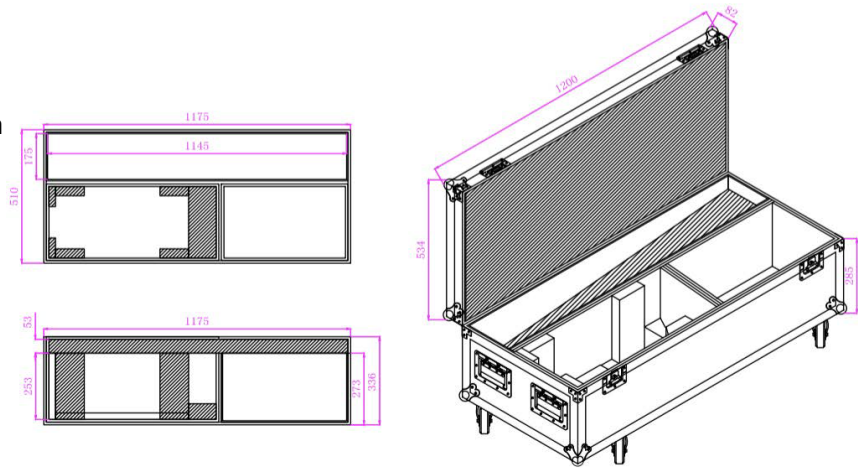

Construction

9mm Red Hex Pattern Wood 6 layer

Penn ElCom Hardware

4 Medium Receded Black Handles

8 Large Black Ball Corners

2 Medium Black Automatic Latch

2 Medium Black Lid Stays

4 4" Magnetic Castors

4 Black Castor Stacking Dish

1 Label Dish (with Generic Mega Case Label)

1 Stand Storage Compartment

1 Cable Storage Compartment

Foam Lined

PHYSICAL SIZE:

Size: 47" x 21" x 20

Weight: 82 lb